



CL2-A1 Chlorine Sensor



PATENTED

Figure 1 CL2-A1 Schematic Diagram

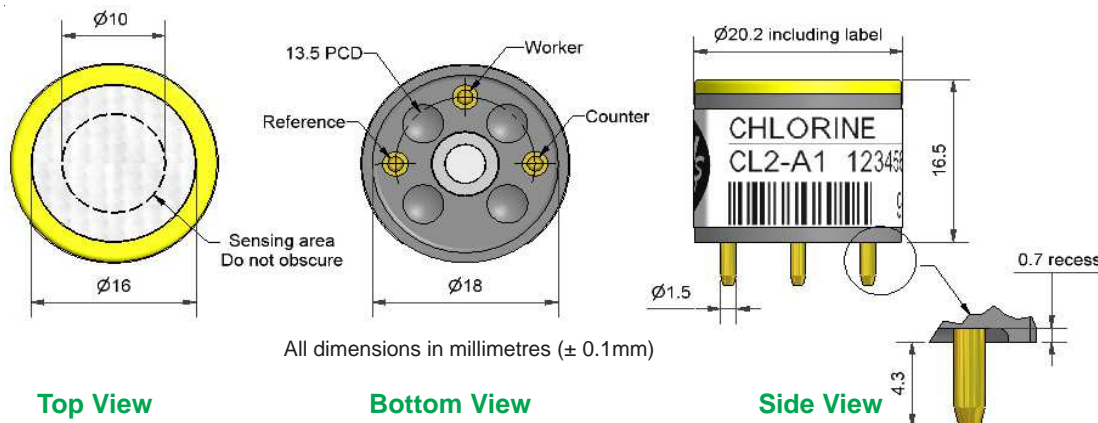

Technical Specification

PERFORMANCE	Parameter	Specification	Range
	Sensitivity	nA/ppm in 10ppm Cl ₂	-350 to -750
	Response time	t ₉₀ (s) from zero to 10ppm Cl ₂ (33Ω load resistor)	< 60
	Zero current	ppm equivalent in zero air	± 0.4
	Resolution	RMS noise (ppm equivalent, 33Ω load resistor)	< 0.02
	Range	ppm limit of performance warranty	20
	Linearity	ppm error at full scale, linear at zero and 5ppm Cl ₂	± 1.5
	Overgas limit	maximum ppm for stable response to gas pulse	50

LIFETIME	Parameter	Specification	Range
	Zero drift	ppm equivalent change/year in lab air, monthly test	< 0.05
	Sensitivity drift	% change/year in lab air, monthly test	< 10
	Operating life	months until 80% original signal (24 month warranted)	> 24

ENVIRONMENTAL	Parameter	Specification	Range
	Sensitivity @ -20°C	% (output @ -20°C/output @ 20°C) @ 10ppm Cl ₂	65 to 85
	Sensitivity @ 50°C	% (output @ 50°C/output @ 20°C) @ 10ppm Cl ₂	105 to 125
	Zero @ -20°C	ppm equivalent change from 20°C	< ± 0.2
	Zero @ 50°C	ppm equivalent change from 20°C	< 0 to -0.8

CROSS SENSITIVITY	Gas	Sensitivity	Specification	Range
	H ₂ S	sensitivity	% measured gas @ 20ppm	< -300
	NO ₂	sensitivity	% measured gas @ 10ppm	100
	NO	sensitivity	% measured gas @ 50ppm	< 3
	SO ₂	sensitivity	% measured gas @ 20ppm	< -8
	CO	sensitivity	% measured gas @ 400ppm	< 0.1
	H ₂	sensitivity	% measured gas @ 400ppm	< 0.1
	C ₂ H ₄	sensitivity	% measured gas @ 400ppm	< 0.1

KEY SPECIFICATIONS	Parameter	Specification	Range
	Temperature range	°C	-20 to 50
	Pressure range	kPa	80 to 120
	Humidity range	%rh continuous	15 to 90
	Storage period	months @ 3 to 20°C (stored in sealed pot)	6
	Load resistor	Ω (for optimum performance)	33
	Weight	g	< 6



At the end of the product's life, do not dispose of any electronic sensor, component or instrument in the domestic waste, but contact the instrument manufacturer, Alphasense or its distributor for disposal instructions.

Apollosense Ltd



CL2-A1 Performance Data

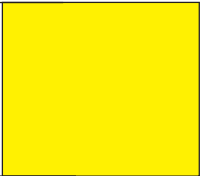

Technical Specification

Figure 2 Sensitivity Temperature Dependence

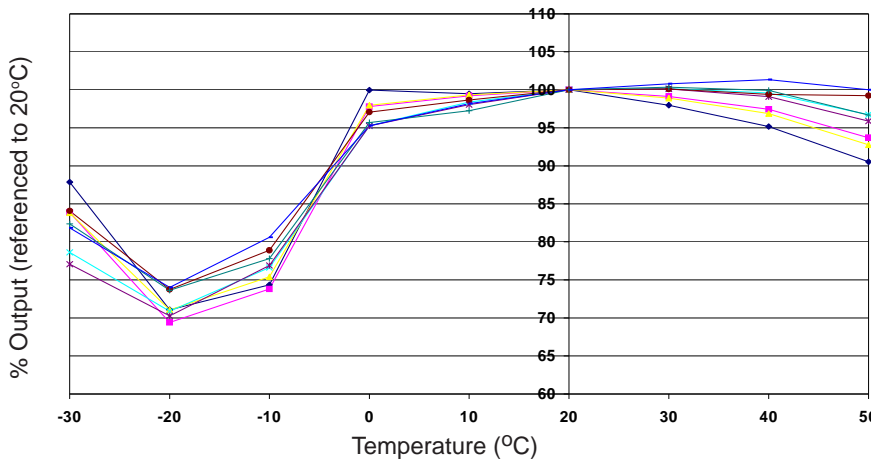

Figure 2 shows the variation in sensitivity caused by changes in temperature.

This data is taken from a typical batch of sensors. The mean and 95% confidence intervals are shown.

Chlorine gas tests are difficult, especially at higher temperatures.

Figure 3 Zero Temperature Dependence

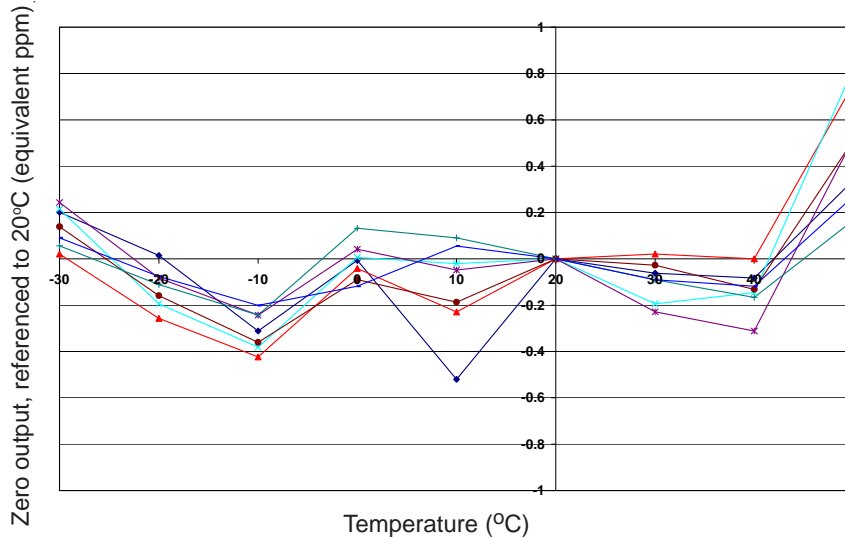

Figure 3 shows the variation in zero output caused by changes in temperature, expressed as ppm gas equivalent, referenced to zero at 20°C.

This data is taken from a typical batch of sensors.

Figure 4 Response to 10ppm Cl₂ changes with temperature

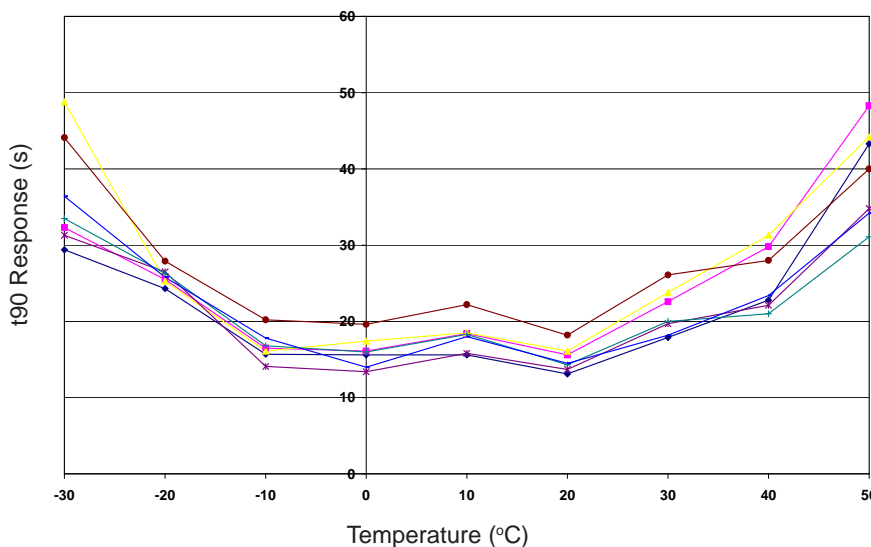

Figure 4 shows the response time temperature dependence for a typical batch of sensors.

Normally the response time increases as the temperature decreases, but for chlorine it also increases at higher temperatures, reflecting the complex chemistry.

ApolloSense Ltd